

THE SHAPE OF THINGS TO COME

 **CDD**TM
COAXIAL DIFFERENTIAL DISPERSION SERIES



Unite Your Audience
The Martin Audio Experience





THE CDD SERIES: THE SHAPE OF THINGS TO COME

Martin Audio brings engineering innovation to installed sound with the all-new CDD™ Series — combining distinctive curved enclosures with unique Coaxial Differential Dispersion™ technology to deliver class-leading performance, fidelity and coverage consistency to venues that demand the ultimate in cutting-edge technology and style at a commercial price that makes sense.

Whether it's a bar, an AV installation, a church or a prestige nightclub — the CDD Series has it covered. CDD is the one-stop solution with six two-way full-range coaxial systems — from the micro CDD5 to the powerful CDD15 — complemented by high-performance subwoofers able cover practically all install applications. Now with CDD-Weatherised option, those applications are extended even further.

The CDD Series has the audience covered too. Coaxial Differential Dispersion technology delivers more consistent audience coverage than systems with fixed dispersion $X^\circ \times Y^\circ$ horns — projecting more output to the rear of the audience to distribute sound evenly front-to-back, while having wide horizontal coverage close-up. This increased coverage area can reduce the speaker count in larger installations by up to 25% thereby significantly reducing total installation cost of a project.

Visually-appealing enclosure design is a signature of the CDD Series. The full-range enclosures can be used in either horizontal or vertical orientation, with rotation of the coaxial driver easily accomplished by removing the screw-free, protective grille. The curved shape of each full-range enclosure allows it to be discreetly mounted close to a wall or ceiling.

In summary, architects are happy with the discreet design and often fewer speakers; system integrators are happy as they can provide exemplary coverage for spaces and competitive tenders that increases the number of jobs that can be won; and the quality of coverage and consistency not only delights the client but also their clientele. No wonder, CDD is the shape of things to come.

Photos: *Top-left* – Burger & Lobster Bar and Grill
Right – White Water Rafting Centre
Bottom-left – Edenton United Methodist Church
Bottom-centre – Tiger Tiger Nightclub





CDD FEATURES

- Versatile, passive, two-way systems
- Coaxial 'point source' performance
- Differential Dispersion™ technology for consistent coverage
- Sleek UPM Formi composite enclosures (except CDD5)
- User-rotatable coaxial drive units
- Vertical and horizontal mounting options
- Screw-free perforated steel grilles
- 8Ω nominal impedance
- Discreet mounting accessories
- Integral inserts for eyebolt suspension of CDD10, CDD12 and CDD15

APPLICATIONS

- Live music clubs
- Music bars
- Nightclubs
- Bars and restaurants
- Museums and AV spaces
- Convention centres
- Hotels
- Retail outlets
- Leisure centres
- Houses of Worship



Photos: *Left* – Faith Free Will Baptist Church
Top – Tiger Niger Nightclub
Bottom – Plopsa Land Amusement Park

All models available in Black or White as standard.
DX0.5 controller is shown.

COAXIAL DIFFERENTIAL DISPERSION™: THE BEST OF BOTH WORLDS

CDD combines the 'point-source' benefits of coaxial designs with the consistent coverage of Differential Dispersion technology. All CDD Series full-range models feature Martin Audio's unique, patent-pending Coaxial Differential Dispersion™ technology to deliver perfect sound to every member of the audience.



• CDD12 Driver

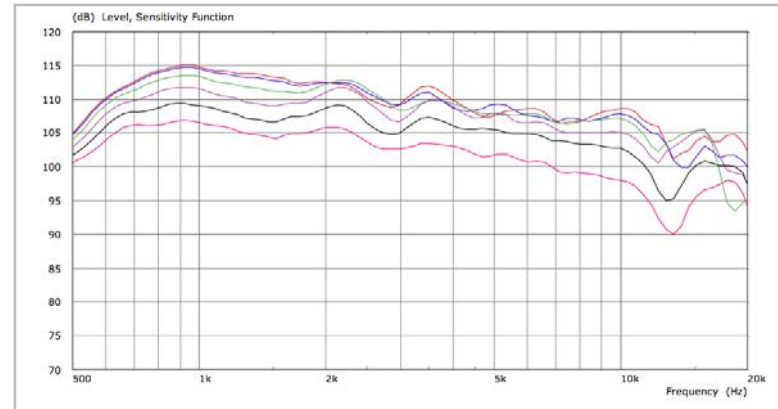

- 0/10/20/30/40/50 degree off-axis measurements of CDD15 (wide-axis). Constant beamwidth maintained up to 20kHz.

THE COAXIAL ADVANTAGE

Non-coaxial systems can suffer from uneven frequency response in the crossover region because the outputs of the LF and HF sections interfere with each other, causing variations off-axis, depending on the listening position. This is especially true close to the loudspeaker.

In contrast, coaxial systems can achieve 'point-source' summation of the LF and HF sections at all positions off-axis, even close-up. This is one reason that coaxial devices are often used for nearfield applications such as studio monitoring.

Significantly, until now one disadvantage of conventional coaxial devices has been high frequency beaming, where the high frequency dispersion reduces as the frequency increases. This is primarily because conventional coaxial devices channel high frequencies through a narrow tube in the pole-piece of the magnet system. CDD Series coaxial devices overcome this by incorporating an innovative static waveguide that merges seamlessly with the unique cone shape — maintaining the dispersion pattern out to very high frequencies.

THE DIFFERENTIAL DISPERSION™ ADVANTAGE

A Differential Dispersion horn has a 3D trapezoid dispersion pattern which covers a room more evenly than a system with a conventional, fixed-dispersion $X^\circ \times Y^\circ$ type horn.

With a conventional $X^\circ \times Y^\circ$ horn, the speaker is usually placed above head height and aimed towards the centre of the audience. This produces an imperfect coverage pattern which misses out some areas — particularly side areas close to the loudspeaker.

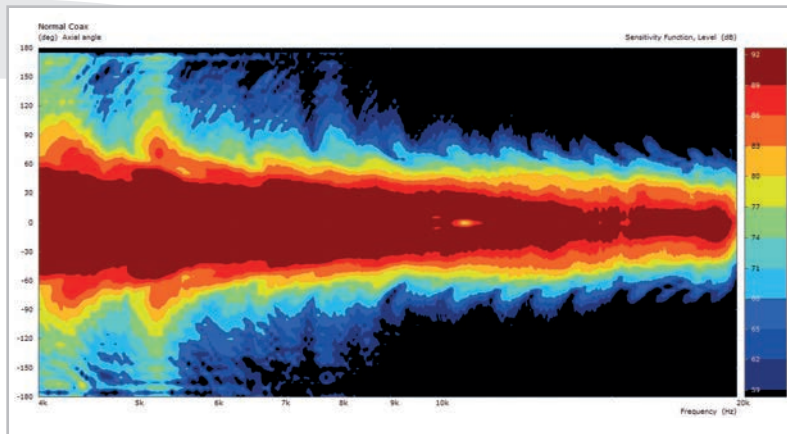

• Conventional coaxial beamwidth

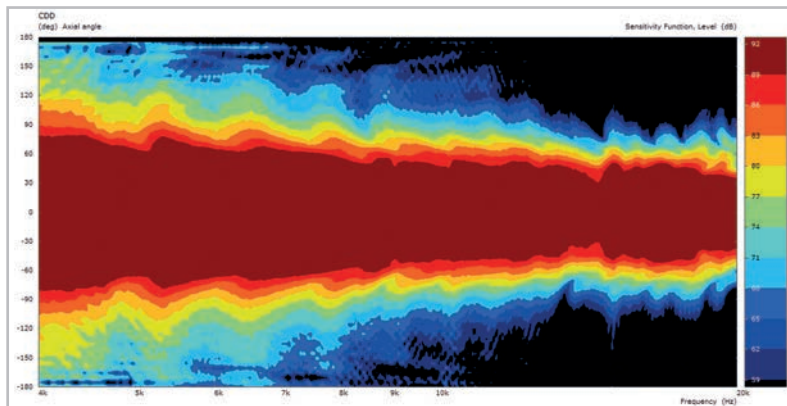

• CDD beamwidth (horizontal)

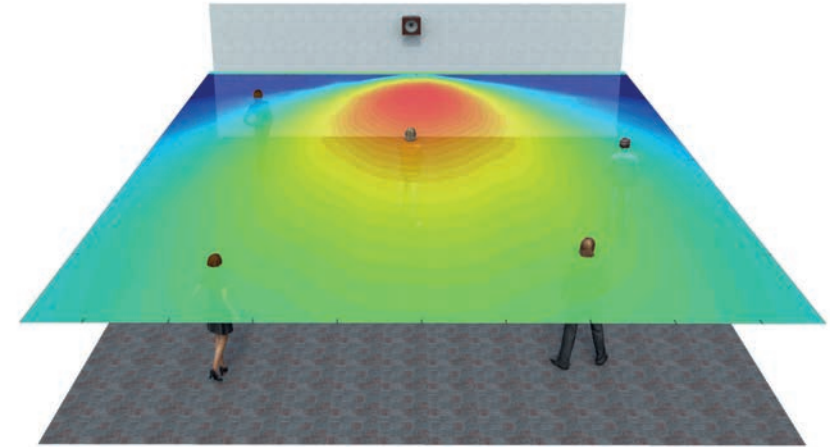

• Conventional $X^\circ \times Y^\circ$ coverage

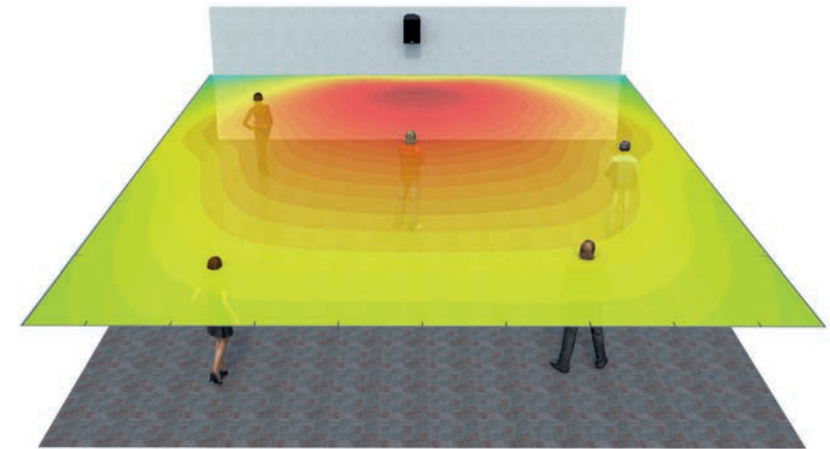

• CDD coverage

In contrast, a CDD Coaxial Differential Dispersion system produces a rectangular coverage pattern to reach all corners of the audience, and wide horizontal coverage is achieved very close to the loudspeaker. Walking the room, the consistency in frequency response and SPL — both close to the loudspeaker and further back — is exceptional. The improved coverage close-up also means that CDD speakers can be spaced further apart in some instances, reducing overall speaker count.

CDD FULL-RANGE SYSTEMS

CDD full-range enclosures have curved surfaces which enable them to be mounted close to ceilings and walls in both horizontal and vertical orientation. With the exception of CDD5, all the enclosures are moulded in rigid UPM Formi — a natural fibre composite material which combines stiffness with excellent internal damping properties. From the CDD8 upwards, speaker baffles are machined from birch ply and all models feature sophisticated internal rib structures to reduce weight and increase rigidity. Finished in black or white as standard, the enclosures can be supplied in any RAL colour to order. Weatherised variants are also available.



CDD5

The CDD5 is a two-way passive micro speaker designed for discreet positioning in architectural installations — including bars, museums, foyers, concourses, exhibition centres and HoW. It features a unique, patent-pending 5" (125mm) LF/0.7" (19mm) HF Coaxial Differential Dispersion driver in an ABS moulded enclosure and is supplied with a dedicated omni-directional mounting bracket. Its screw-free grille can be easily removed to rotate the coaxial driver for horizontal or vertical use. The CDD5TX-WR option incorporates a 70V/100V line transformer and weatherised protection.

CDD6

The ultra-compact CDD6 is a two-way passive loudspeaker system designed to fulfil the requirement for full-frequency dynamic performance from a very small enclosure. Featuring a 6.5" (165mm) LF/1" (25mm) HF Coaxial Differential Dispersion driver, its extremely small size and sleek lines make it ideal for visibly-unobtrusive applications. It can also be used as a fill system in conjunction with larger CDD Series models and, with the addition of a CSX subwoofer, can reproduce surprisingly high levels of music program. The CDD6TX-WR option incorporates a 70V/100V line transformer and weatherised protection.

CDD8

The CDD8 is an ultra-compact two-way passive loudspeaker system with an integrated 8" (200mm) LF/1" (25mm) exit HF Coaxial Differential Dispersion driver which can be easily rotated for horizontal or vertical orientation depending on venue design requirements. Its small size gives no indication of its high output capability. As a stand-alone loudspeaker, it has a multitude of applications and can also be incorporated as an infill loudspeaker in distributed systems using larger CDD models, such as the CDD12 and CDD15. The CDD8-WR option offers weatherised protection.

CDD10

The CDD10 is a very compact two-way passive loudspeaker system which utilises a 10" (250mm) LF/1" (25mm) exit HF Coaxial Differential Dispersion driver. It is uniquely placed to meet the foreground requirements of music bars and clubs, as well as the varied architectural applications that require upfront sound levels from a very compact enclosure. Use with a CSX118 or CSX218 subwoofer will enable the CDD10 to operate as small dancefloor system that is remarkably powerful for its size. Like all CDD full-range systems, its distinctive, curved enclosure is designed for installation very close to walls and ceilings. The CDD10-WR option offers weatherised protection.



CDD12

The CDD12 is a compact, passive two-way system designed for installations that require high output levels. Its high-specification 12" (300mm) LF /1" exit HF Coaxial Differential Dispersion driver delivers perfect sound across the audience over medium-throw distances. The LF driver has a 2.5" (65mm) voice coil and efficient motor with an aluminium demodulating ring to minimise distortion, while the HF driver utilises a 1.75" (44mm) polyimide diaphragm and features a low-compression phaseplug to reduce non-linearity. The CDD12-WR option offers weatherised protection.

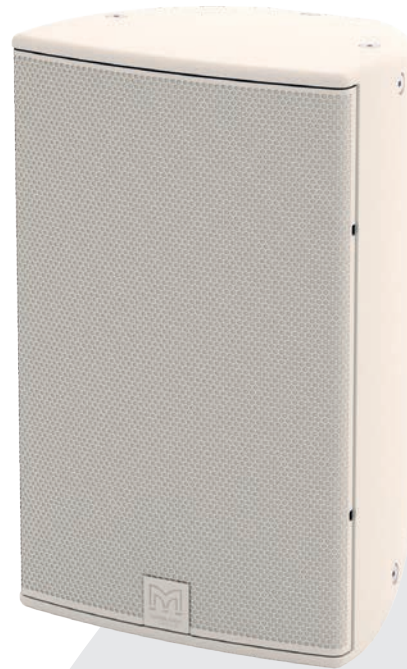

CDD15

Ideal for medium-to-large rooms, the CDD15 is a very high-power, passive two-way system designed for installations that demand the ultimate in sonic performance from a single enclosure. It combines very high output capability with exceptional fidelity and coverage consistency. Its coaxial drive unit comprises a powerful 15" (380mm)/3" (75mm) voice coil LF driver and a 1.4" (35mm) exit HF compression driver with a 3" (75mm) pure titanium diaphragm. The CDD15-WR option offers weatherised protection.



Note: CDD Series full-range systems may be used without a controller. However, the EQ and limiter functions of a controller such as the Martin Audio DX0.5 or DX4.0, or DSP configured MA Series amplifiers will maximise their capabilities.

CSX SUBWOOFERS

Four powerful subwoofers support CDD Series full-range models for applications that require increased low frequency output. When CSX subwoofers are used with CDD full-range systems, crossover and EQ functions can either be performed by the DX0.5 or DX4.0 system controllers, or by an iKON amplifier. All CSX enclosures are now fitted with flying points as standard. Finished in black or white as standard, the enclosures can be supplied in any RAL colour to order. Optional weatherised variants in black or white only are also available.

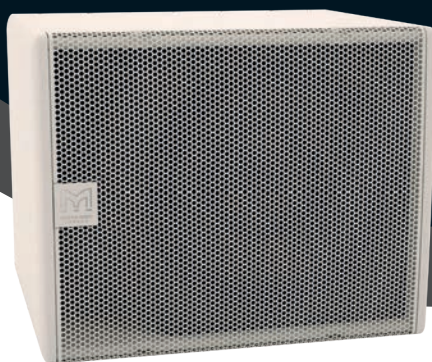

CSX112

The CSX112 is an ultra-compact direct radiating sub-bass system designed to extend the bandwidth and increase the headroom of CDD full-range models from the CDD5 to the CDD10. It features a very efficient 12" (300mm) long-throw bass driver with a high power 3" (75mm) voice coil and generously-sized reflex ports for low noise, high power operation. With a response of 48Hz-150Hz \pm 3dB, the ultra-compact size of the CSX112 makes it an ideal partner for CDD Series systems where space is at a premium or where the subwoofers need to be hidden. The enclosure is constructed from high-density MDF and has an impact-resistant finish, while the driver is protected by a rigid perforated steel grille. The CSX112-WR option offers weatherised protection.



CSX212

With twin high-efficiency 12" (300mm)/3" (75mm) voice coil long-throw bass drivers and optimally-sized reflex ports to minimise air noise, the CSX212 is the perfect sub-bass where low frequency extension and impact is required from a very compact, unobtrusive, low-profile enclosure. The CSX212 is designed to be used with CDD Series full-range systems from the CDD5 to the CDD12 and extends the low frequency operating range of the combined system down to 40Hz. The enclosure is constructed from high-density MDF and is internally-braced to reduce energy transmission to the enclosure panels and baffle. It is finished in textured paint and its perforated steel grille is pre-curved to withstand damage. The CSX212-WR option offers weatherised protection.



CSX118

The CSX118 is a compact, high performance subwoofer that extends the low frequency operating range of the combined system to 35Hz and provides exceptional low frequency impact. An ideal partner for the CDD10, CDD12 and CDD15, it features a long-excursion 18" (460mm)/4" (100 mm) voice coil driver with a water-resistant cone and triple roll surround in a compact reflex enclosure. The design of the 18" driver maximises output while minimising power compression and distortion, and the four reflex ports have a large frontal area to reduce turbulent air noise at very high levels. The enclosure is constructed from high-density MDF and finished in white or black textured paint as standard. The CSX118-WR option offers weatherised protection.

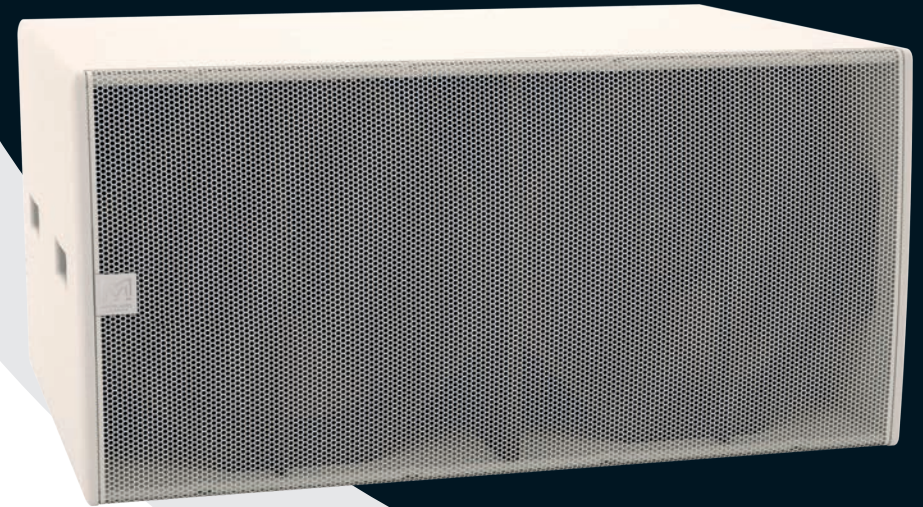

CSX218

The CSX218 achieves the ultimate in subwoofer performance for the most prestigious CDD Series applications – delivering very high output levels and superb transient performance with minimal distortion. With an operating range of 35Hz-150Hz \pm 3dB, it houses dual 18" long-excursion (460mm)/4" (100mm) voice coil drivers with water-resistant cones and triple roll surrounds. Each driver is rated to handle 1000 watts AES, and has a magnet structure and suspension engineered for maximum linear excursion. The enclosure of the CSX218 is constructed from high-density MDF and coated with hard-wearing textured paint. Eight reflex ports provide a large frontal area to reduce turbulent air noise, and a perforated steel grille protects the drivers from damage with minimal obstruction of airflow. The CSX218-WR option offers weatherised protection.

INSTALLATION OPTIMISED

With the CDD Series, innovative technology, class-leading performance and sleek lines are complemented by versatile mounting options, ease of installation and a comprehensive range of practical mounting accessories. The curved shape of the full-range systems has been designed to enable CDD enclosures to be mounted very close to a wall or ceiling in both horizontal and vertical orientations. All brackets can come as weatherised option.

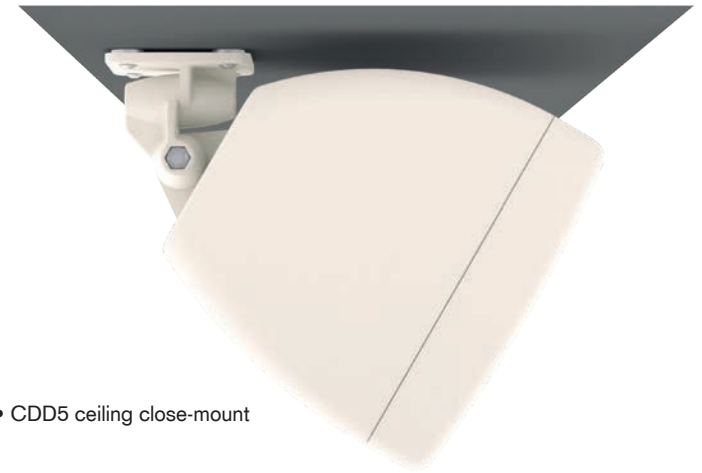

• CDD5 ceiling close-mount



• CDD5 tilt and pan landscape



• CDD10 tilt and pan portrait



• CDD10 wall mount



• CDD yoke assembly

SPECIAL COLOUR OPTIONS

CDD Series standard colour options are black (RAL9005) and white (RAL9016). Models supplied custom-painted in any RAL colour are by special order.



• CDD12 in RAL6005 moss green

ACCESSORIES

ITEM NUMBER	DESCRIPTION
WB6/8B	CDD6/CDD8 WALL BRACKET BLACK
WB6/8W	CDD6/CDD8 WALL BRACKET WHITE
WB10/12B	CDD10/CDD12 WALL BRACKET BLACK
WB10/12W	CDD10/CDD12 WALL BRACKET WHITE
CDDCB5B	CDD5 CEILING BRACKET BLACK
CDDCB5W	CDD5 CEILING BRACKET WHITE
CDDCB6/8B	CDD6/CDD8 CEILING BRACKET BLACK
CDDCB6/8W	CDD6/CDD8 CEILING BRACKET WHITE
CDDYA10B*	CDD10 YOKE ASSEMBLY BLACK
CDDYA10W*	CDD10 YOKE ASSEMBLY WHITE
CDDYA12B*	CDD12 YOKE ASSEMBLY BLACK
CDDYA12W*	CDD12 YOKE ASSEMBLY WHITE
CDDYA15B*	CDD15 YOKE ASSEMBLY BLACK
CDDYA15W*	CDD15 YOKE ASSEMBLY WHITE

*Note: Yoke brackets are designed for use in landscape orientation only

EASE DATA

To assist system design and speaker placement within a venue, high-resolution GLL files for CDD Series models are downloadable from the Martin Audio website www.martin-audio.com

CDD Weatherised

The CDD Series in black or white is also available in weather-resistant form. Like many on the market, CDD-WR loudspeakers and CSX-WR subwoofers are designed for outdoor operation where it will be subject to changing environmental conditions, but sheltered from direct exposure to the elements. Weatherised mounting brackets are also available.



a box for all seasons

Available from May 2016
Full tech specifications available at www.martin-audio.com



CDD-WR FEATURES

- Loudspeakers feature water and particle resistant grille (zinc plated mild steel with powder coated finish)
- Operating temperature -20°C to +70°C
- Environmentally tested to meet IP54
- CDD5TX-WR and CDD6TX-WR feature dual cable gland for easy daisy-chaining of cabinets without the need for external breakout boxes
- CDD5TX-WR and CDD6TX-WR also feature 100/70v line transformer
- CDD8-WR thru CDD15-WR feature single cable gland on input cover
- CDD10-WR through CDD15-WR are flyable with fixings made from stainless steel
- Weatherised mounting brackets are also available

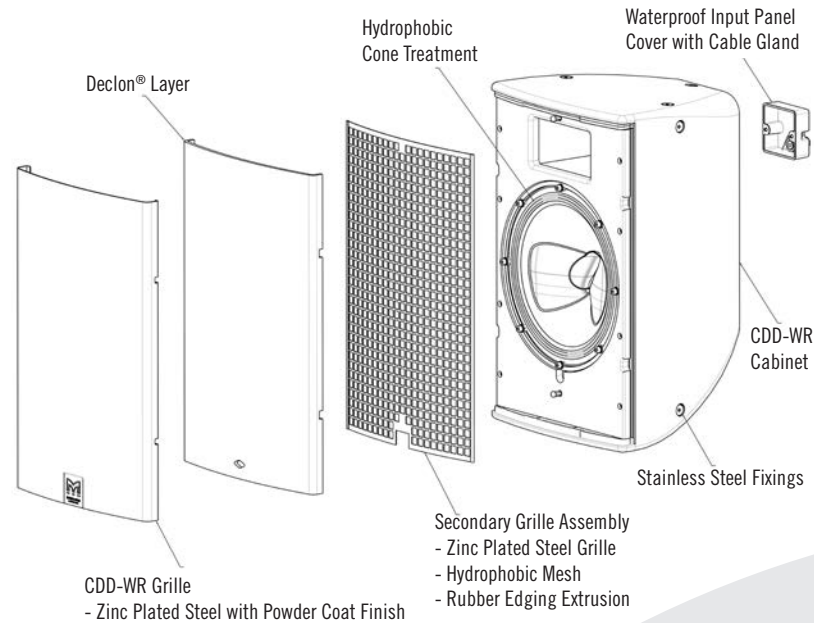

CSX-WR FEATURES

- Subwoofers feature zinc plated mild steel grille with powder coated finish
- Plywood cabinets with polyurea coating
- Operating temperature -20°C to +70°C
- Environmentally tested to meet IP24
- Subwoofers are flyable with fixings made from stainless steel

APPLICATIONS

- Outdoor restaurants, bars and hotel areas
- Nearfield systems in outdoor stadia, transport hubs, concourses and theme parks



TECHNICAL SPECIFICATIONS

CDD5

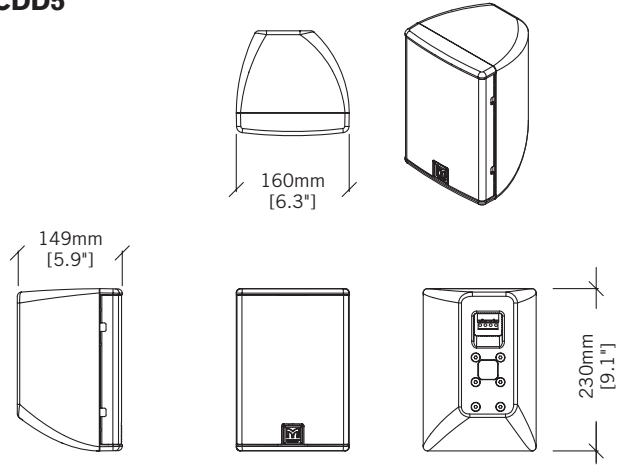

CDD6

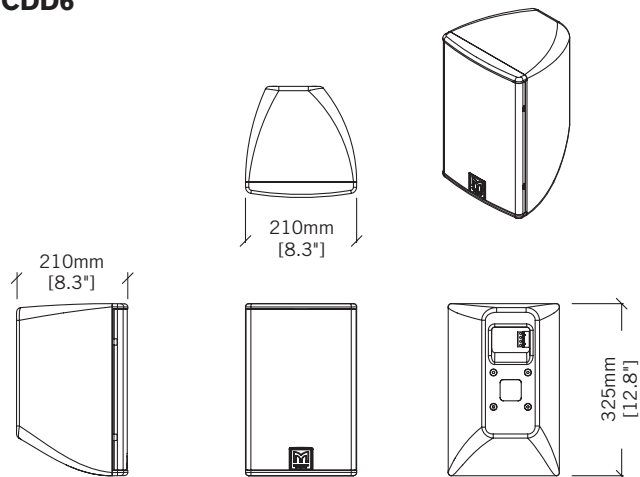

CDD8

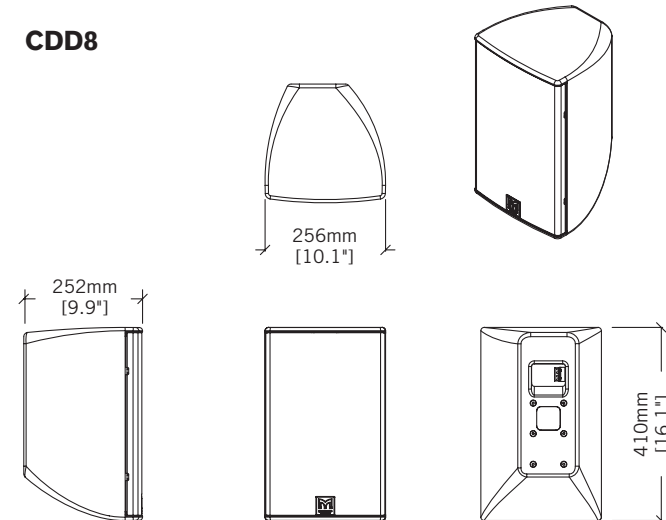

	CDD5	CDD6	CDD8
TYPE	Ultra-compact, Coaxial Differential Dispersion passive two-way system	Ultra-compact, Coaxial Differential Dispersion passive two-way system	Ultra-compact, Coaxial Differential Dispersion passive two-way system
FREQUENCY RESPONSE (5)	100Hz-20kHz \pm 3dB, 10dB @ 70Hz	80Hz-20kHz \pm 3dB, -10dB @ 70Hz	70Hz-20kHz \pm 3dB, -10dB @ 55Hz
DRIVER	LF: 5.25" (130mm)/1.25" (32mm) voice coil, long excursion, ferrite motor system HF: 0.75" (19mm) voice coil, fabric dome with neodymium motor system	LF: 6.5" (165mm)/1.5" (38mm) voice coil, long excursion, ferrite motor system HF: 1" (25mm) voice coil, fabric dome with neodymium motor system	LF: 8" (200mm)/2" (50mm) voice coil, long excursion, shared ferrite motor system with HF HF: 1" (25mm) exit/1.4" (38mm) voice coil, polyimide dome compression driver
RATED POWER (2)	100W AES, 400W peak	150W AES, 600W peak	200W AES, 800W peak
RECOMMENDED AMPLIFIER	iK81 / VIA2502/2004	iK81 / VIA2502/2004	iK81 / VIA2502/2004
SENSITIVITY (8)	90dB	91dB	94dB
MAXIMUM SPL (9)	110dB continuous, 116dB peak	113dB continuous, 119dB peak	117dB continuous, 123dB peak
NOMINAL IMPEDANCE	8 ohms	8 ohms	8 ohms
DISPERSION (-6dB)	120°-90° horizontal, 80° vertical (user-rotatable)	110°-80° horizontal, 80° vertical (user-rotatable)	110°-80° horizontal, 60° vertical (user-rotatable)
CROSSOVER	2.5kHz passive	2.5kHz passive	2.3kHz passive
ENCLOSURE	3 litre, ABS	9 litre, composite material	14 litre, composite material
FINISH	Black or white	Black or white textured paint	Black or white textured paint
PROTECTIVE GRILLE	Black or white perforated steel with scrim cloth backing	Black or white perforated steel with scrim cloth backing	Black or white perforated steel with scrim cloth backing
CONNECTORS	Low profile 13A push-lock	Low profile 13A push-lock	Low profile 13A push-lock
PIN CONNECTIONS	Left to right: Input+, Input -, Link -, Link +	Left to right: Input+, Input -, Link -, Link +	Left to right: Input+, Input -, Link -, Link +
FITTINGS	6 x M5 inserts for wall/ceiling brackets	4 x M6 inserts for wall/ceiling brackets	6 x M6 inserts for wall/ceiling brackets
DIMENSIONS	(W) 160mm x (H) 230mm x (D) 149mm (W) 6.3ins x (H) 9.1 ins x (D) 5.9 ins	(W) 210mm x (H) 325mm x (D) 210mm (W) 8.3ins x (H) 12.8ins x (D) 8.3ins	(W) 256mm x (H) 410mm x (D) 252mm (W) 10.1ins x (H) 16.1ins x (D) 9.9ins
WEIGHT	3kg (6.6lbs)	5.5kg (12.1lbs)	9.5kg (21lbs)
ACCESSORIES	CDDCB5B ceiling bracket black CDDCB5W ceiling bracket white	CDDWB6/8B wall bracket black CDDWB6/8W wall bracket white CDDCB6/8B ceiling bracket black CDDCB6/8W ceiling bracket white	CDDWB6/8B wall bracket black CDDWB6/8W wall bracket white CDDCB6/8B ceiling bracket black CDDCB6/8W ceiling bracket white

	CDD10	CDD12	CDD15
TYPE	Compact, Coaxial Differential Dispersion passive two-way system	Compact, high-output, Coaxial Differential Dispersion passive two-way system	High-output, Coaxial Differential Dispersion passive two-way system
FREQUENCY RESPONSE (5)	65Hz-20kHz ± 3dB, -10dB @ 55Hz	62Hz-20kHz ± 3dB, -10dB @ 50Hz	55Hz-18kHz ± 3dB, -10dB @ 45Hz
DRIVER	LF: 10" (250mm)/2.5" (63.5mm) voice coil, long excursion, shared ferrite motor system with HF HF: 1" (25mm) exit/1.4" (38mm) voice coil, polyimide dome compression driver	LF: 12" (300mm)/2.5" (63.5mm) voice coil, long excursion, shared ferrite motor system with HF HF: 1" (25mm) exit/1.7" (44mm) voice coil, polyimide dome compression driver	LF: 15" (380mm)/3" (75mm) voice coil, long excursion, shared ferrite motor system with HF HF: 1.4" (36mm) exit/3" (75mm) voice coil, titanium dome compression driver
RATED POWER (2)	250W AES, 1000W peak	300W AES, 1200W peak	400W AES, 1600W peak
RECOMMENDED AMPLIFIER	iK81 / VIA2502/2004	iK81 / VIA2502/5002/5004	iK81 / VIA5002/5004
SENSITIVITY (8)	96dB	97dB	100dB
MAXIMUM SPL (9)	120dB continuous, 126dB peak	122dB continuous, 128dB peak	126dB continuous, 132dB peak
NOMINAL IMPEDANCE	8 ohms	8 ohms	8 ohms
DISPERSION (-6dB)	110°-75° horizontal, 60° vertical (user-rotatable)	110°-60° horizontal, 60° vertical (user-rotatable)	100°-60° horizontal, 60° vertical (user-rotatable)
CROSSOVER	2kHz passive	1.9kHz passive	1.6kHz passive
ENCLOSURE	28 litre, composite material	38 litre, composite material	68 litre, composite material
FINISH	Black or white textured paint	Black or white textured paint	Black or white textured paint
PROTECTIVE GRILLE	Black or white perforated steel with scrim cloth backing	Black or white perforated steel with scrim cloth backing	Black or white perforated steel with scrim cloth backing
CONNECTORS	Low profile 20A push-lock	Low profile 20A push-lock	Low profile 20A push-lock
PIN CONNECTIONS	Left to right: Input+, Input -, Link -, Link+	Left to right: Input+, Input -, Link -, Link+	Left to right: Input+, Input -, Link -, Link+
FITTINGS	6 x M8 inserts for wall bracket 10 x M8 fly points	6 x M8 inserts for wall bracket 10 x M8 fly points	10 x M8 fly points
DIMENSIONS	(W) 323mm x (H) 513mm x (D) 310mm (W) 12.7ins x (H) 20.2ins x (D) 12.2ins	(W) 360mm x (H) 571mm x (D) 350mm (W) 14.2ins x (H) 22.5ins x (D) 13.8ins	(W) 429mm x (H) 691mm x (D) 413mm (W) 16.9ins x (H) 27.2ins x (D) 16.3ins
WEIGHT	15.3kg (33.7lbs)	19.3kg (42.5lbs)	27.7kg (61lbs)
ACCESSORIES	CDDWB10/12B wall bracket black CDDWB10/12W wall bracket white CDDYA10B yoke assembly black CDDYA10W yoke assembly white	CDDWB10/12B wall bracket black CDDWB10/12W wall bracket white CDDYA12B yoke assembly black CDDYA12W yoke assembly white	CDDYA15B yoke assembly black CDDYA15W yoke assembly white

CDD12

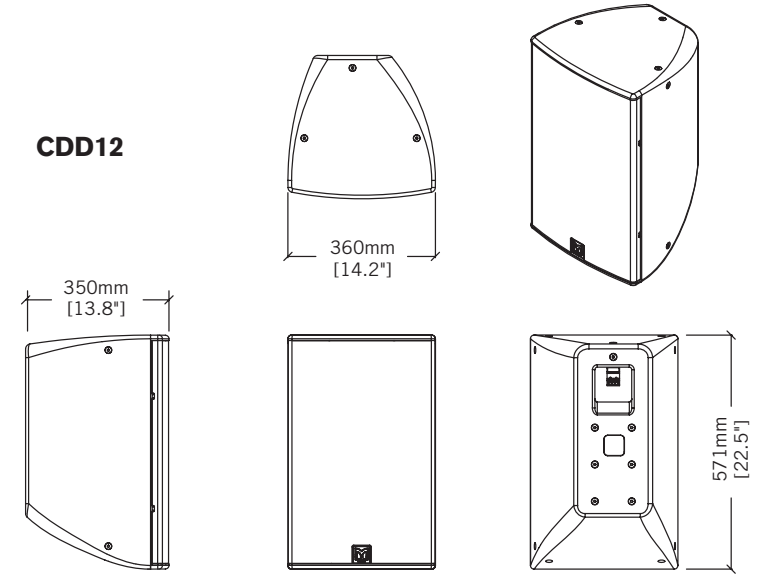

CDD10

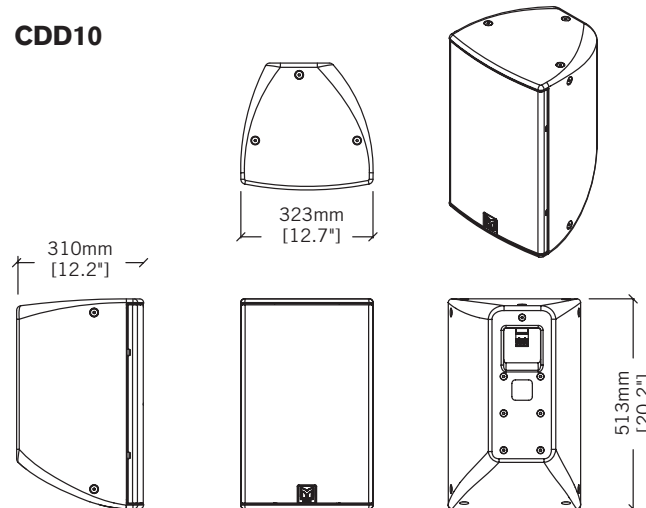

CDD15

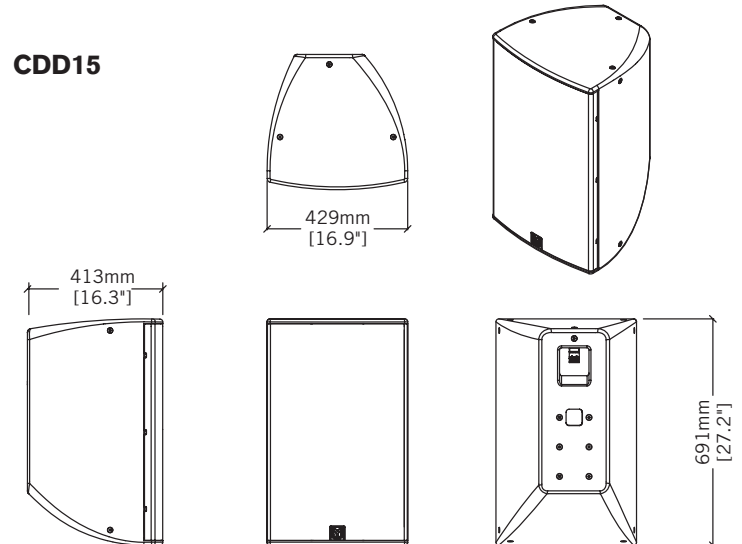

Notes

- (1) Measured on-axis in half (2pi) space at 2 metres, then referred to 1 metre.
- (2) AES Standard ANSI S4.26-1984.
- (3) Measured in half (2pi) space at 2 metres with 1 watt input, using band limited pink noise, then referred to 1 metre.
- (4) Measured in half (2pi) space at 2 metres using band limited pink noise, then referred to 1 metre.
- (5) Measured on-axis in open (4pi) space at 2 metres, then referred to 1 metre.
- (6) Measured in open (4pi) space at 2 metres with 1 watt input, using band limited pink noise, then referred to 1 metre.
- (7) Measured in open (4pi) space at 2 metres using band limited pink noise, then referred to 1 metre.
- (8) Measured in open (4pi) space at 2 metres with 2.83V input, using band limited pink noise, then referred to 1 metre.
- (9) Calculated at 1 metre.
- (10) Measured in half (2pi) space at 2 metres with 2.83V input, using band limited pink noise, then referred to 1 metre.

TECHNICAL SPECIFICATIONS

CSX112

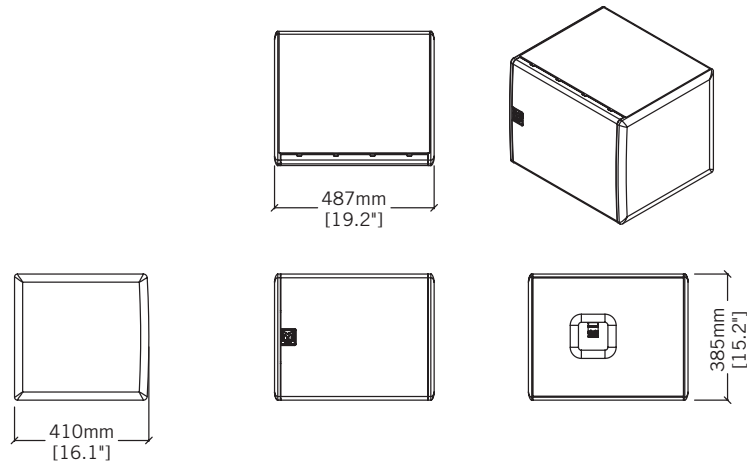

CSX212

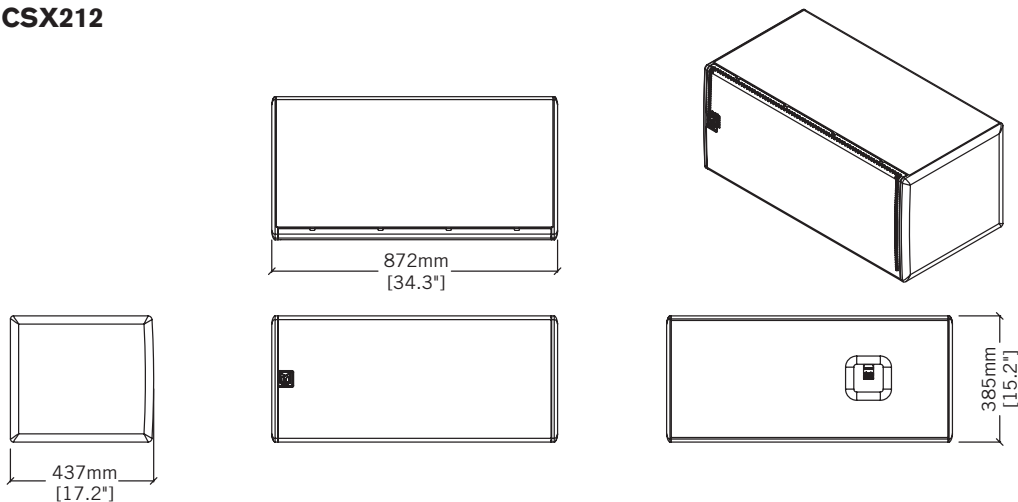

	CSX112	CSX212
TYPE	Compact, single driver, direct radiating subwoofer	Compact, dual-driver, direct radiating subwoofer
FREQUENCY RESPONSE (1)	48Hz-150Hz ± 3dB, -10dB @ 35Hz	48Hz-150Hz ± 3dB, -10dB @ 35Hz
DRIVER	12" (300mm)/3" (75mm) voice coil, long excursion, ferrite magnet, waterproof cone	2 x 12" (300mm)/3" (75mm) voice coil, long excursion, ferrite magnet, waterproof cone
RATED POWER (2)	400W AES, 1600W peak	800W AES, 3200W peak
RECOMMENDED AMPLIFIER	iK81 / VIA2502/5002/5004	iK42 / VIA5002/5004
SENSITIVITY (10)	100dB	106dB
MAXIMUM SPL (9)	126dB continuous, 132dB peak (half space)	132dB continuous, 138dB peak (half space)
NOMINAL IMPEDANCE	8 ohms	4 ohms
DISPERSION (-6dB)	Omnidirectional	Omnidirectional
CROSSOVER	80-120Hz active	80-120Hz active
ENCLOSURE	52 litre, high-density MDF	100 litre, high-density MDF
FINISH	Black or white textured paint	Black or white textured paint
PROTECTIVE GRILLE	Black or white perforated steel	Black or white perforated steel
CONNECTORS	Low profile 20A push-lock	Low profile 20A push-lock
PIN CONNECTIONS	Left to right: Input+, Input -, Link -, Link+	Left to right: Input+, Input -, Link -, Link+
DIMENSIONS	(W) 487mm x (H) 385mm x (D) 410mm (W) 19.2ins x (H) 15.2ins x (D) 16.1ins	(W) 872mm x (H) 385mm x (D) 437mm (W) 34.3ins x (H) 15.2ins x (D) 17.2ins
WEIGHT	21.5kg (47.3lbs)	39kg (86lbs)

	CSX118	CSX218
TYPE	Compact, direct radiating subwoofer	Dual-driver, direct radiating subwoofer
FREQUENCY RESPONSE (1)	40Hz-150Hz ± 3dB, -10dB @ 35Hz	35Hz-150Hz ± 3dB, -10dB @ 30Hz
DRIVER	18" (460mm)/4" (100mm) voice coil, long excursion, ferrite magnet, waterproof cone	2 x 18" (460mm)/4" (100mm) voice coil, long excursion, ferrite magnet, waterproof cone
RATED POWER (2)	1000W AES, 4000W peak	2000W AES, 8000W peak
RECOMMENDED AMPLIFIER	iK42 / VIA5002/5004	iK42 / VIA5002/5004
SENSITIVITY (10)	102dB	108dB
MAXIMUM SPL (9)	132dB continuous, 138dB peak (half space)	138dB continuous, 144dB peak (half space)
NOMINAL IMPEDANCE	8 ohms	4 ohms
DISPERSION (-6dB)	Omnidirectional	Omnidirectional
CROSSOVER	80-120Hz active	80-120Hz active
ENCLOSURE	160 litre, high-density MDF	330 litre high-density MDF
FINISH	Black or white textured paint	Black or white textured paint
PROTECTIVE GRILLE	Black or white perforated steel	Black or white perforated steel
CONNECTORS	Low profile 20A push-lock	Low profile 20A push-lock
PIN CONNECTIONS	Left to right: Input+, Input -, Link -, Link+	Left to right: Input+, Input -, Link -, Link+
FITTINGS		Four pocket handles
DIMENSIONS	(W) 530mm x (H) 662mm x (D) 640mm (W) 20.9ins x (H) 26.1ins x (D) 25.2ins	(W) 1085mm x (H) 530mm x (D) 780mm* (W) 42.7ins x (H) 20.9ins x (D) 30.7ins* *911mm (35.9ins) with wheels
WEIGHT	42kg (93lbs)	84kg (185lbs)

Notes

- (1) Measured on-axis in half (2pi) space at 2 metres, then referred to 1 metre.
- (2) AES Standard ANSI S4.26-1984.
- (3) Measured in half (2pi) space at 2 metres with 1 watt input, using band limited pink noise, then referred to 1 metre.
- (4) Measured in half (2pi) space at 2 metres using band limited pink noise, then referred to 1 metre.
- (5) Measured on-axis in open (4pi) space at 2 metres, then referred to 1 metre.
- (6) Measured in open (4pi) space at 2 metres with 1 watt input, using band limited pink noise, then referred to 1 metre.
- (7) Measured in open (4pi) space at 2 metres using band limited pink noise, then referred to 1 metre.
- (8) Measured in open (4pi) space at 2 metres with 2.83V input, using band limited pink noise, then referred to 1 metre.
- (9) Calculated at 1 metre.
- (10) Measured in half (2pi) space at 2 metres with 2.83V input, using band limited pink noise, then referred to 1 metre.

CSX118

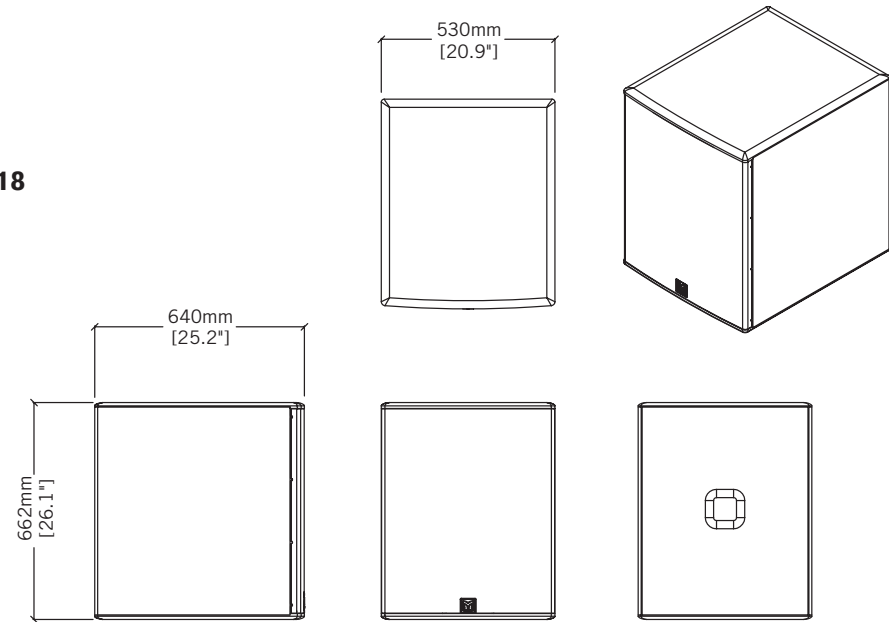

CSX218

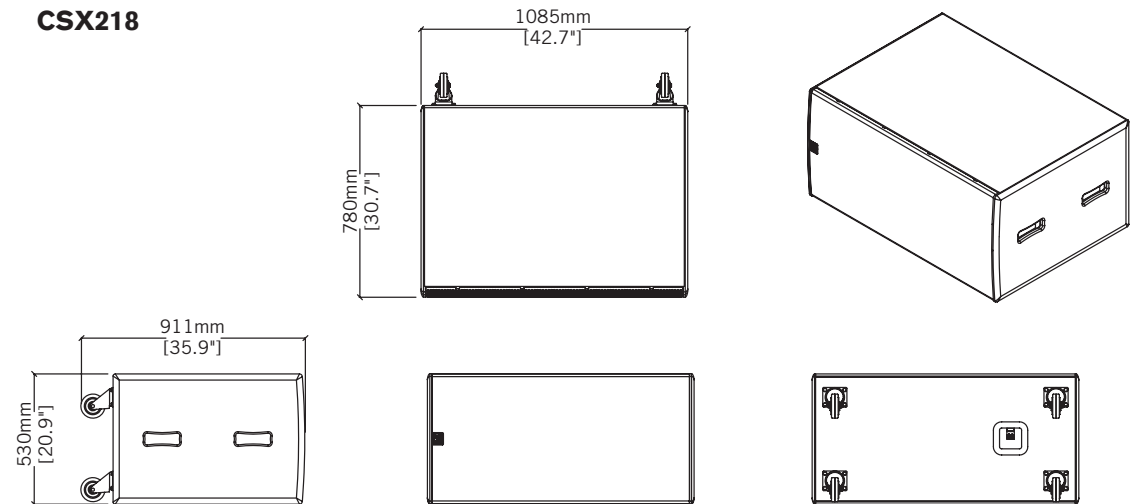



THE SHAPE OF THINGS TO COME

Martin Audio Limited

Century Point

Halifax Road

Cressex Business Park

High Wycombe

Buckinghamshire

HP12 3SL

England

FOR SALES ENQUIRIES:

UK

Telephone: +44 (0)1494 535312

E-mail: info@martin-audio.com

NORTH AMERICA

Telephone: 818 649 7776

All information is Copyright © 2017 Martin Audio Ltd.

Martin Audio, the Martin Audio logo and Hybrid are registered trademarks of Martin Audio Ltd. in the United Kingdom, United States and other countries; all other Martin Audio trademarks are the property of Martin Audio Ltd.

www.martin-audio.com

Unite Your Audience
The Martin Audio Experience

Version 3.1